



XL | RANGE

radial piston motors

ROTARY POWER has over 35 years experience in the design and development of high quality Hydraulic equipment.

Our current product range includes :-

"A" Axial Piston Pumps for heavy-duty open circuit applications. Wide range of controls. Excellent life characteristics. Suitable for most fluids, including HLP,HFA, HFB, HFC ,HFD, HFR , HFE , Isocyanates & Polyols. Fixed and variable capacities from 11.5 to 125 cm³/rev.

"C" Axial Piston Pumps for high accuracy fluid metering with precision flow controls and high-pressure capability. Specifically designed for the Polyurethane Industry. Capacities from 3 to 62 cm³/rev.

"XL" Cam Motors of radial piston configuration. Wheel/shaft/torque module configurations. Design offers high-speed capability. Capacities from 150 to 1120 cm³/rev.

"XK" Cam Motors radial piston configuration offering static/dynamic brakes, single/2 speed, wheel/shaft & torque-module mount options.

Heavy-Duty External Load & High-Speed options. Capacities from 1000 to 5000 cm³/rev.

"SMA" Motors heavy-duty radial piston/eccentric configuration, offering excellent life. Withstands high mechanical and hydraulic shock loads. 350bar Continuous pressure rating. Speed & power ratings significantly greater than standard HTLS motors.

Displacements from 150 to 10500 cm³/rev.

Wholly owned subsidiaries in the USA and Germany and a network of distributors throughout the world provide product support in most countries.

ROTARY POWER is a company within British Engines Ltd (BEL) group, which was established over 60 years ago.

The British Engines group of companies design manufacture and market a wide range of engineered products for offshore, electrical, construction, engineering and other industries, employing nearly 700 people on a 4600 sq m site in Newcastle upon Tyne, England.

FEATURES

Modular Concept

- Common torque unit
- 4 standard output options
- Over 20 optional output options

Freewheel

- True freewheel possible
- Recirculating freewheel possible

High-Torque Start

- Efficient piston roller design
- Pintle valving reduces mechanical losses

Total Reversibility

- Equal torque in both directions

Compact Installation

- Multi-stroking radial piston design
- Minimum overall dimensions
- High power-to-weight ratio

High Pressure Capability

- Designed to operate at up to 420 bar peak pressure

Low Inertia

Higher capacity lower speed drives :

- Reduced inertia enables rapid reversals and speed changes
- Reduced mechanical losses in geared drives
- Reduced noise

Service

XL designed for easy service :

- Fully interchangeable components
- Few special tools needed
- Split mechanical and torque functions

Reliability

XL developed from over 20 years' experience in industries such as :

- Construction
- Defence
- Brewing
- Food Production
- Mining
- Steel Production
- Offshore
- Municipal

XL COMPACT PISTON MOTORS

OUTPUT CONFIGURATIONS

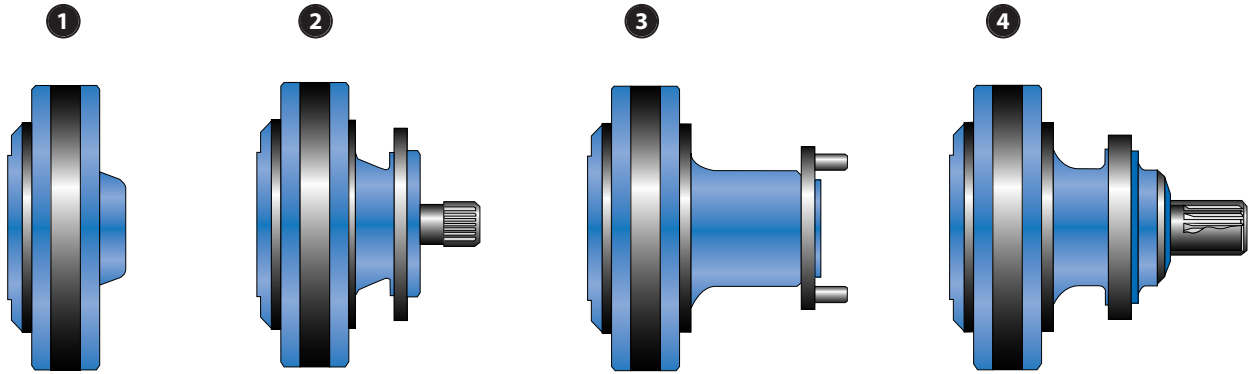

XL motors may be supplied in the four configurations shown above. It is possible to supply a shaft motor with wheel housing if required.

Which configuration to use :-

1.	Torque Unit	No axial / radial loading. Integration into machine / gearbox drives - mobile / industrial.
2.	Compact Motor	Light or no axial / radial loading and gearbox drives - mobile / industrial.
3.	Wheel Motor	High radial / axial loading and long life - mobile / industrial.
4.	Shaft Motor	High radial / axial loading and long life - mobile / industrial.

XL MOTOR OPERATION

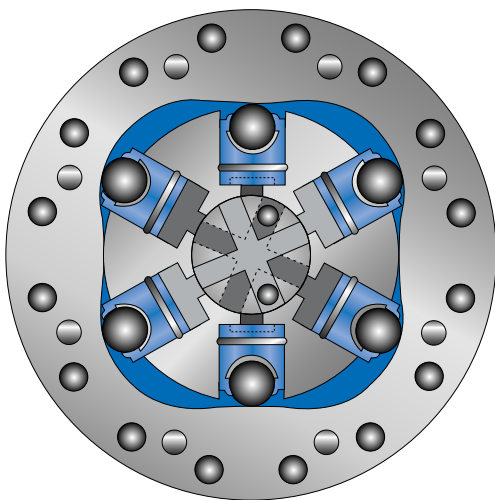

Oil is fed under pressure through the valve and into the cylinders. The pistons attempt to move outwards. The rollers react on the incline of the cam profile and this action produces rotation of the cylinder block.

Each piston completes four strokes per revolution of the motor. The symmetrical arrangement balances hydraulic forces, eliminating the need for bearings.

X L R A D I A L P I S T O N M O T O R S

XL MOTOR TECHNICAL DATA

		XL150	XL200	XL280	XL390	XL490	XL560	XL780	XL880	XL980	XL1050	XL1120
Geometric Displacement	(CM3)	150	200	280	390	490	560	780	880	980	1050	1120
Max Speed Rev/Min	Cont.	550	500	390	440	350	320	230	200	180	170	160
	Int*	600	600	550	500	500	450	320	285	255	240	225
	Freewheel	1000	1000	1000	850	850	850	850	850	850	850	850
Max Torque (Nm)	Cont	480	640	890	1250	1570	1790	2500	2820	3140	3355	3680
	Int*	790	1050	1480	2060	2590	2590	4120	4650	5180	5530	5900
	Peak**	930	1240	1740	2420	3040	3460	4840	5460	6080	6480	6920
Max Output kW	Cont	18	18	18	30	30	30	60	60	60	60	60
	Int*	30	30	30	50	50	50	100	100	100	100	100
Max Pressure (Bar)	Cont	210	210	210	210	210	210	210	210	210	210	210
	Int*	350	350	350	350	350	350	350	350	350	350	350
	Peak**	420	420	420	420	420	420	420	420	420	420	420
Max Oil Flow (L/Min)	Cont	87	105	109	178	178	178	178	178	178	178	178
	Int*	95	128	154	205	251	251	251	251	251	251	251
Outlet Pressure (Bar)***	Min	2	2	2	2	2	2	2	2	2	2	2
	Max	20	20	20	20	20	20	20	20	20	20	20
Case Pressure (Bar)	Max	7	7	7	7	7	7	7	7	7	7	7
Fluid Type		HL; HLP to DIN 51524 (for alternative fluid types contact Rotary Power)										
Fluid Min/Max Viscosity		15 to 2000 cSt										
Optimum Viscosity		35 to 200 cSt										
Operating Temp (°C) Min/Max		-30°C to +80°C										
Optimum		+40°C to +70°C										
Fluid Cleanliness		NAS 1638 Class 9/ISO Code 18/15										
FILTRATION		TO b10 RATIO 75 OR BETTER										
Min Starting Torque (Nm)	At 210 Bar Press. Cont.	420	560	790	1100	1390	1580	2210	2500	2780	2980	3180
	At 350 Bar Press. Cont.	710	940	1320	1840	2320	2640	3670	4140	4610	4940	5270

* Permissible intermittent values may occur for up to 10% of every minute as part of a known duty cycle (Typical maximum pressure for mobile applications).

** Peak loads may occur for up to 1% of every minute.

*** Outlet Pressure required above case pressure.

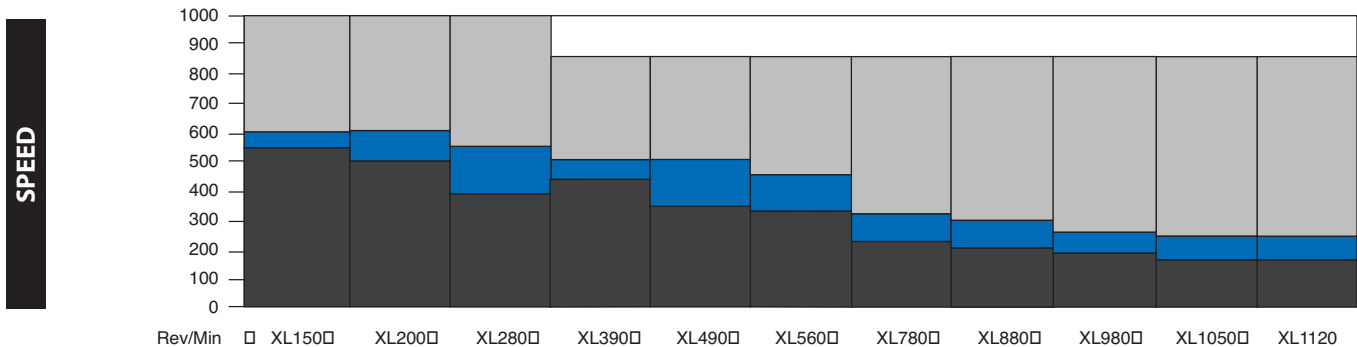
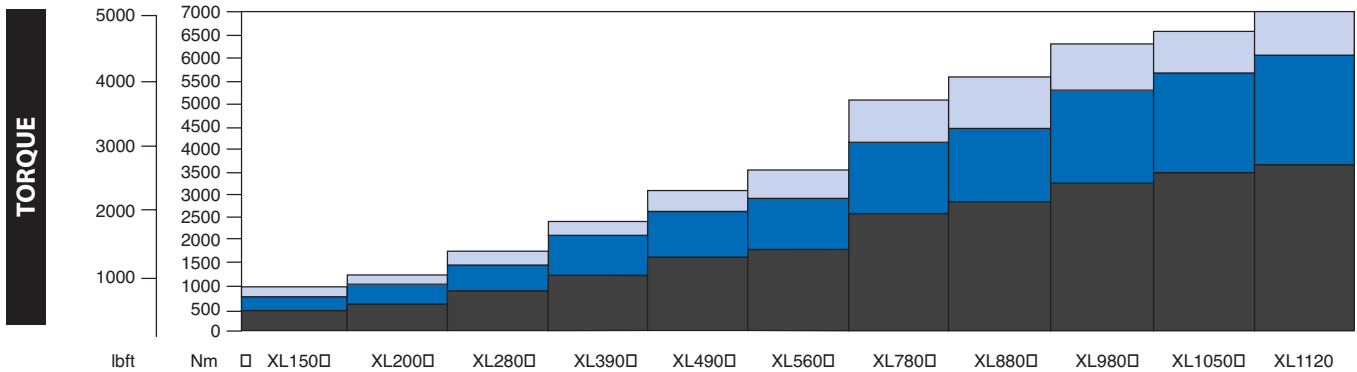

Peak Values
 Intermittent Values
 Freewheel Values
 Continuous Values



PERFORMANCE DATA - POWER CHARTS

Power capabilities for XL motors are indicated in the charts shown. These should be read in conjunction with the information given in the technical data chart. For optimum life, continuous periods of operation should be limited to the grey area on the charts.

Mobile transmissions and industrial drives may use values up to maximum stated intermittent speeds pressures and powers shown as part of an anticipated duty cycle. ISO efficiencies shown are intended to assist in designing transmission systems. Allowance should be made for normal reduction in efficiencies as a system ages.

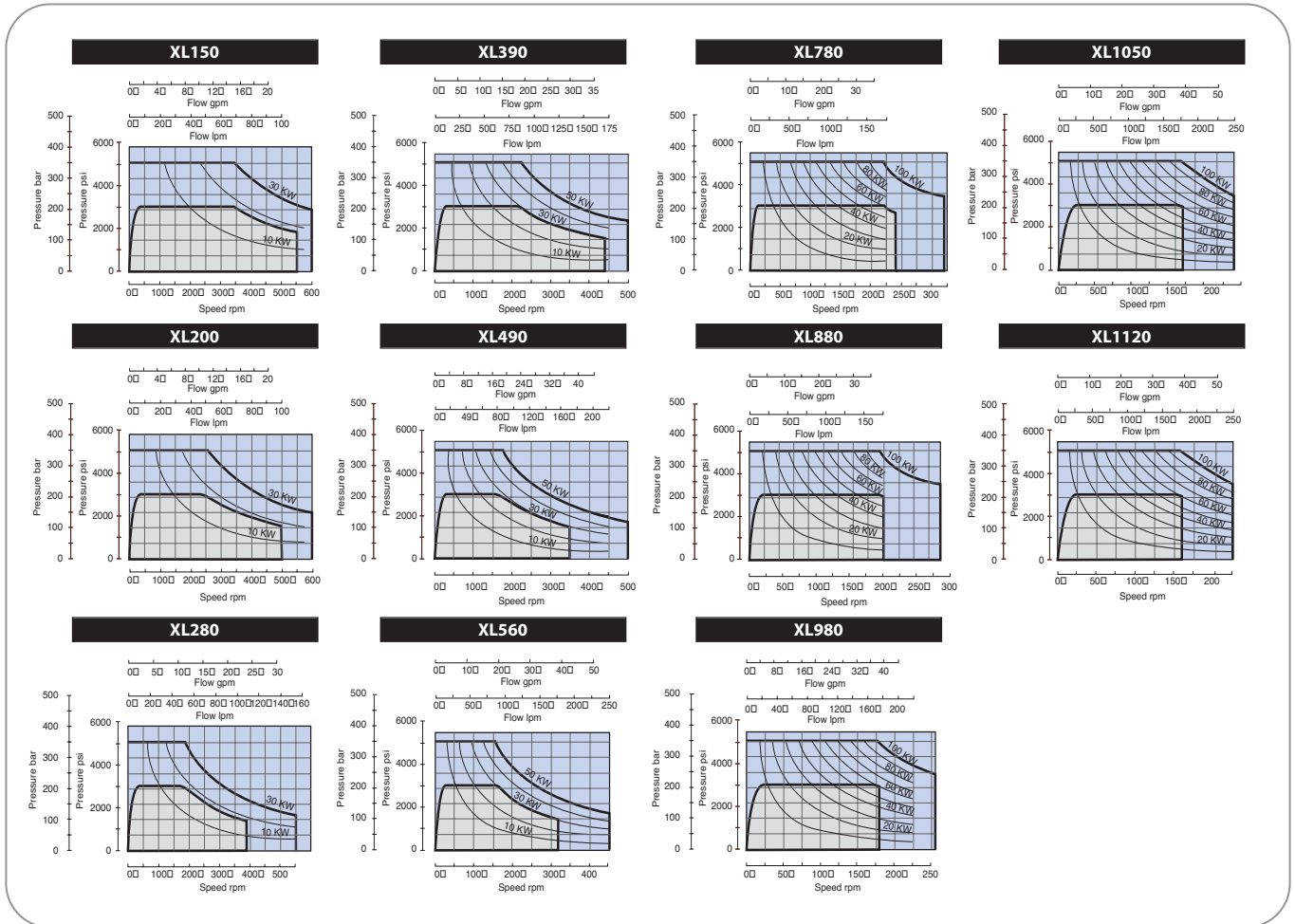

CALCULATIONS

DETERMINATION OF MOTOR SIZE

Output torque = $\frac{\text{Motor displacement} \times \Delta \text{ pressure} \times \eta_m}{20\pi}$

Flow required for rotational speed:

Flow = $\frac{\text{Motor displacement} \times \text{rotational speed}}{1000 \times \eta_v}$

Output power = $\frac{\text{Motor torque} \times \text{rotational speed}}{9550}$

Units

- Torque = Nm.
- Flow = L/min.
- Power = kW.
- ΔPressure = Bar
- Speed = Rev/min.
- Motor displacement = cm³ per revolution
- η_m = Mechanical efficiency.
- η_v = Volumetric efficiency.

For approximate estimates of performance η_m = 0.95; η_v = 0.95. These can be assumed as typical values for 50% of maximum continuous speed and 275 bar Δpressure.

PERFORMANCE DATA

CASE DRAIN FLOW

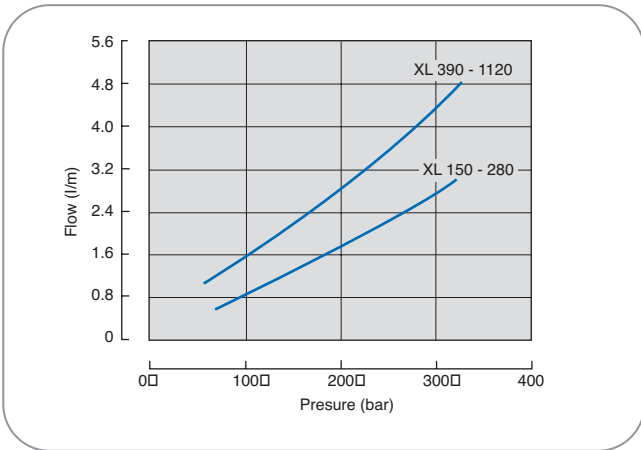

Case drain figures should be added to other circuit losses in closed loop systems to arrive at loop make-up requirements. Installation should be designed to prevent siphoning of oil from the motor case.

Where continuous operation is above 300 min⁻¹ it may be necessary to provide a cooling flow through the case, typically 1-2 litres/min. The need for cooling flow depends upon duty, fluid environment etc.

Case drain is located on the pintle and should be positioned uppermost.

NO LOAD PRESSURE DROP

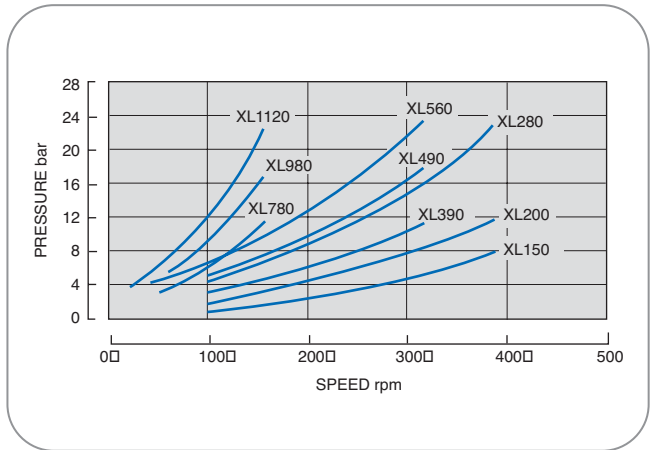

The differential pressure across the supply ports required to drive the motor over its speed range with the output shaft disconnected.

BOOST PRESSURE

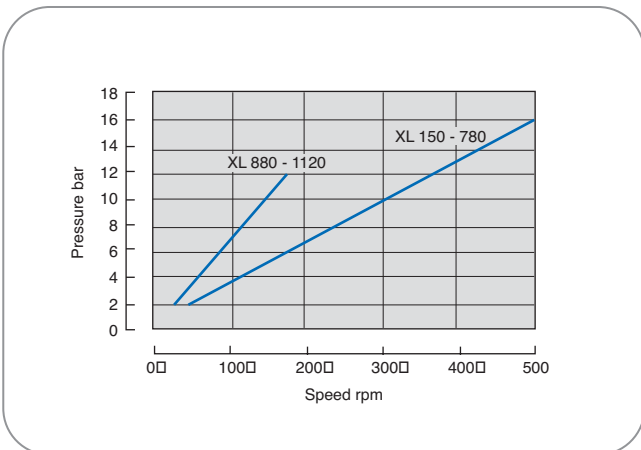

Where the load can overrun the motor (i.e. motor operating as a pump) it is important to ensure sufficient supply boost pressure to avoid incomplete filling of the cylinders and cavitation. The minimum boost pressure required at the motor inlet port is equal to the sum of the boost pressure from the graph and the actual case pressure.

FREE WHEELING

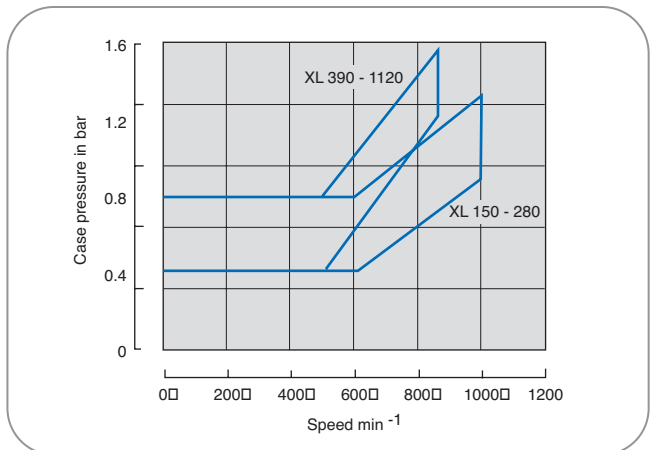

Case pressure (differential over port pressure) required to retract the pistons for freewheeling operation is shown in the graph above. The transition into and out of the freewheeling mode is normally accomplished with the motor stationary.

OUTPUT CONFIGURATIONS

WHEEL AND SHAFT MOTORS

Type XLA XLB XLE

Output shafts run in taper bearings that permit high axial and radial forces. Due to the unique design of the XL, the shaft bearings are not affected by system pressure.

Compact Motor

Even though this is a type XLC lightweight output housing moderate radial and axial loading is permissible. The curves apply to a B10 bearing life of 3000 hours at 110 rev/min when mineral-based hydraulic oil with anti-wear additions and to specification DIN 51424 is used. The graphs are drawn for a 40cSt oil.

Effect of shaft speed on life

Because L10 life and speed are inversely proportional to each other, bearing life for speeds other than 110 rpm can easily be calculated, i.e. half speed gives twice life. To calculate the bearing life for a different speed :

$$L_{10 \text{ new}} = 3000 \times \frac{110 \text{ rev/min}}{\text{new rev/min}}$$

Effect of shaft load on life

If the radial load is less than that shown by the curve, bearing life will be longer than 3000 hours. Assuming the speed is set at 110 rev/min (if not, adjust as shown above) bearing life may be calculated using :

$$L_{10 \text{ new}} = 3000 \times \left[\frac{\text{curve load}}{\text{new load}} \right]^{3.33^\circ}$$

Effect of shaft speed on permissible shaft load

Applications such as vehicle propulsion using wheel motors can produce conditions of high load and relatively low speed. In such conditions permissible shaft load must always remain within the mechanical strength limitations.

To calculate permissible shaft load :

$$\text{New load} = \text{Load from curve} \times 3.33 \sqrt{\frac{110}{\text{new speed}}}$$

If you are in any doubt contact Rotary Power Applications Department.

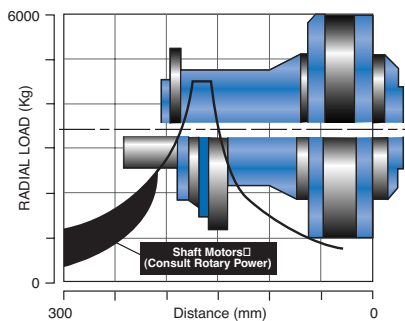

XL 150 200 180

Note : Right hand portion of above graph is based on fatigue limit for shaft in rotating bending.

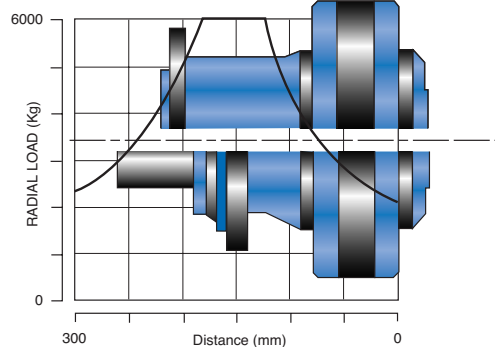

XL 390 490 560

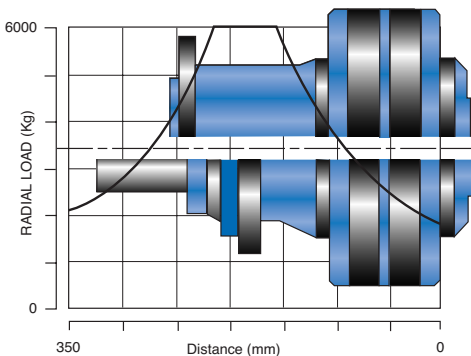

XL 780 880 980 1050 1120

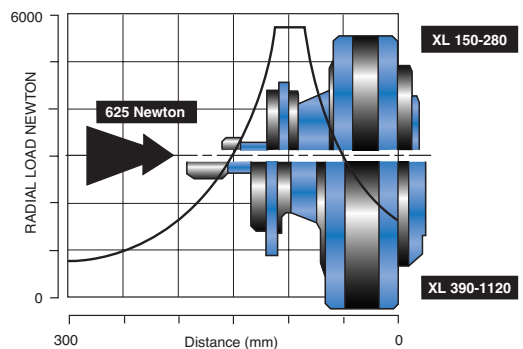

XL COMPACT

XLA XLB SHAFT MOTORS

Before finalising your installation please ask for a copy of the latest issue drawing.

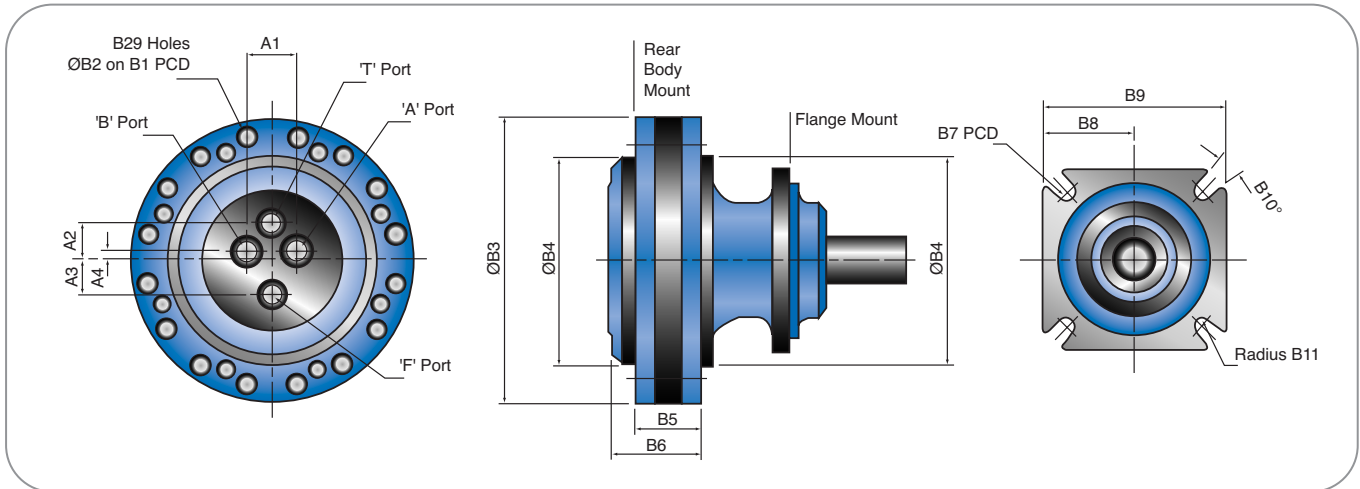

XLA _ A _ 000 --

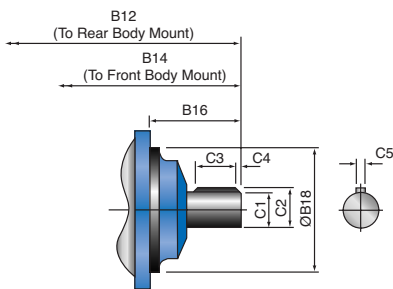

XLB _ B _ 000 --

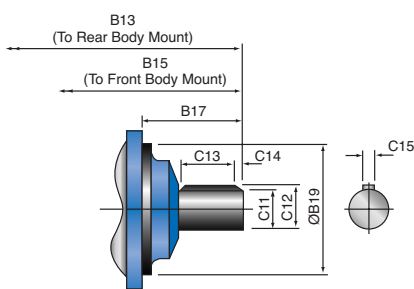

XLB _ F _ 000 --

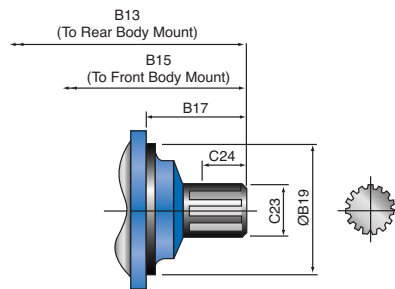

XLA _ D _ 000 --

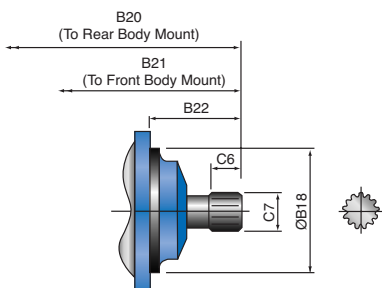

XLB _ C _ 000 --

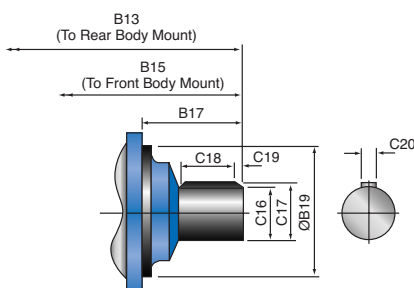

XLA _ H _ 00 --

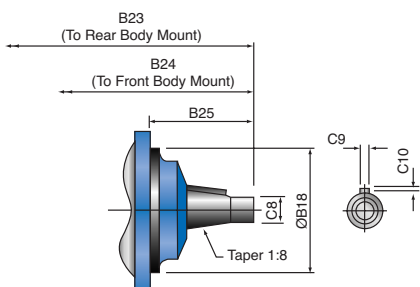

XLB _ E _ 000 --

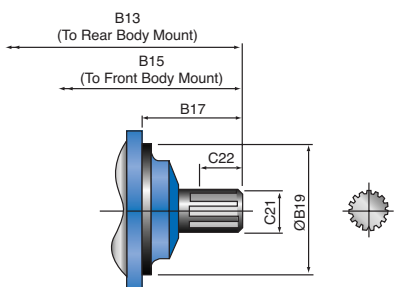



DIMENSIONS XLA XLB SHAFT MOTORS

HYDRAULIC CONNECTIONS			
	XL150 XL200 XL280	XL390 XL490 XL560	XL780 XL980 XL1120
* 'A' Port	5/8 SAE J514	5/8 SAE J514	5/8 SAE J514
* 'B' Port	5/8 SAE J514	5/8 SAE J514	5/8 SAE J514
* 'T' Port	3/8 SAE J514	1/2 SAE J514	1/2 SAE J514
* 'F' Port	3/8 SAE J514	1/2 SAE J514	1/2 SAE J514
A1	45	52	52
A2	33	38	38
A3	28	36	36
A4	5.5	9	9

MOUNTING INFORMATION			
	XL150 XL200 XL280	XL390 XL490 XL560	XL780 XL980 XL1120
B1	210	265	265
B2	14.25/13.90	17.75/17.40	17.75/17.40
B3	237	298	298
B4	180.0/179.95	216.0/215.82	216.0/215.82
B5	62	70	105
B6	84	95	130
B7	160	200	200
B8	74	95	95
B9	148	190	190
B10	17°	11°	11°
B11	7	9	9
B12	270.0	270.2	N/A
B13	270.0	285.5	320.5
B14	208.0	200.2	N/A
B15	208.0	215.5	250.5
B16	118.6	110.2	N/A
B17	114.0	122.5	122.5
B18	127.0/126.95	152.4/152.35	152.4/152.35
B19	125.0/124.94	160.0/159.94	160.0/159.94
B20	242.0	270.2	N/A
B21	180.0	200.2	N/A
B22	90.6	110.2	N/A
B23	270.0	285.5	320.5
B24	208.0	215.5	250.5
B25	118.6	125.5	125.5

OUTPUT SHAFT INFORMATION			
	XL150 XL200 XL280	XL390 XL490 XL560	XL780 XL980 XL1120
C1	38.1/38.05	44.45/44.4	N/A
C2	42.4/42.14	49.30	N/A
C3	70.0	50.0	N/A
C4	5.0	5.0	N/A
C5	9.55/9.53	11.14/11.11	N/A
C6	26.0	36.0	N/A
C7	ANSI B92.1 17T 12/24P	ANSI B92.1 13T 8/18P	N/A
C8	1 1/8-12 UNF	1 1/4-12 UNF	1 1/4-12 UNF
C9	9.55/9.53	11.14/11.11	11.14/11.11
C10	4.93/4.67	5.715/5.461	5.715/5.461
C11	40.018/40.002	50.018/50.002	N/A
C12	43.018/42.759	53.518/53.212	N/A
C13	70.0	70.0	N/A
C14	5.0	5.0	N/A
C15	12.0/11.91	14.043/14.0	N/A
C16	50.018/50.002	65.03/65.01	65.03/65.01
C17	53.40	68.90	68.90
C18	70.0	65.0	65.0
C19	5.0	10.0	10.0
C20	14.0/13.96	18.0/17.96	18.0/17.96
C21	DIN5480 W40x3x12x7H	DIN5480 W50x3x15x7H	N/A
C22	50.0	53.0	N/A
C23	BS3550 17T 8/16P	BS3550 14T 6/12P	BS3550 14T 6/12P
C24	50.0	54.0	54.0

* Hydraulic connection sizes denote SAE 'O' ring boss size. These are not thread dimensions.

X L R A D I A L P I S T O N M O T O R S

WHEEL DRAWINGS

Before finalising your installation please ask for a copy of the latest issue drawing.

WHEEL MOTORS 150 - 560 CC/REV

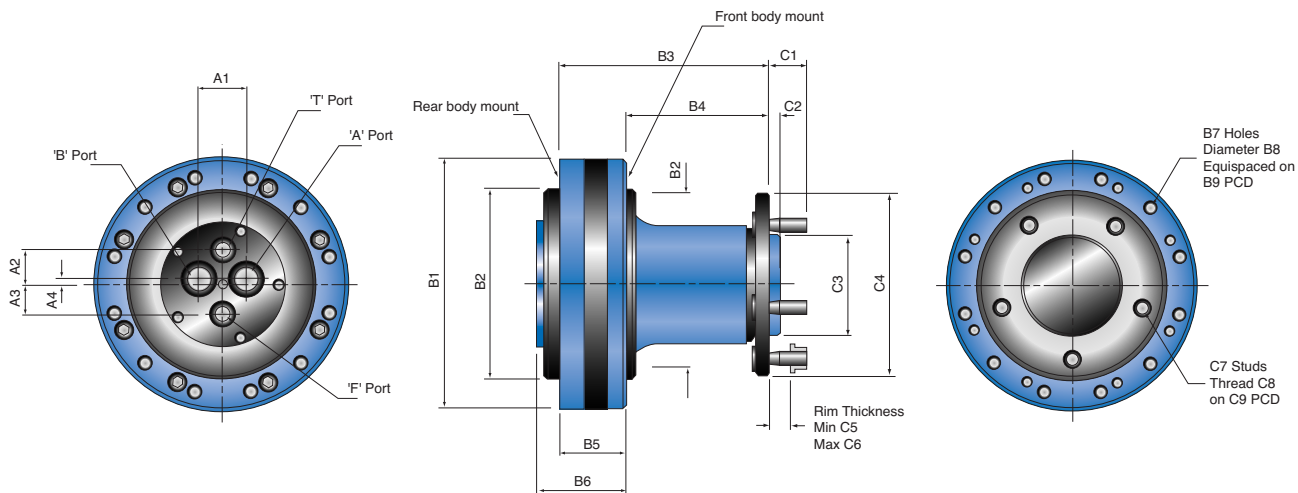

WHEEL MOTORS 780 - 1120 CC/REV

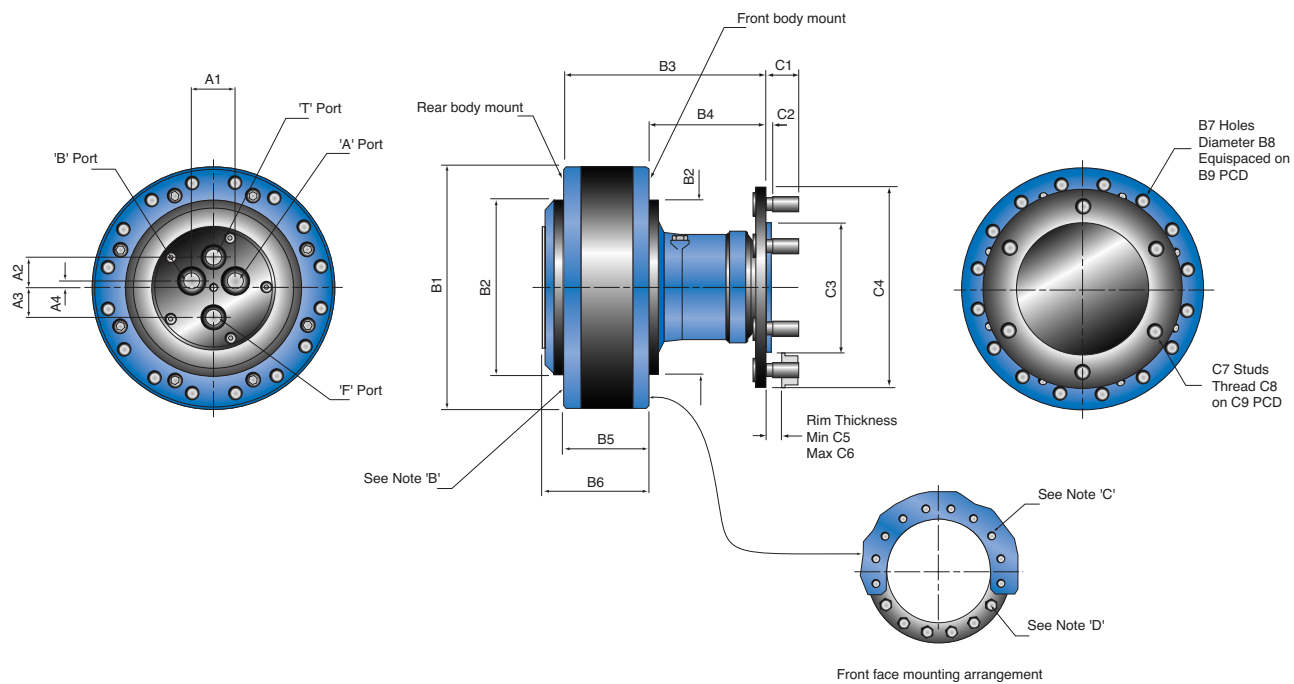

WHEEL DIMENSIONS

HYDRAULIC CONNECTIONS			
	XL150 XL200 XL280	XL390 XL490 XL560	XL780 XL980 XL1120
*'A' Port	5/8 SAE J514	5/8 SAE J514	5/8 SAE J514
*'B' Port	5/8 SAE J514	5/8 SAE J514	5/8 SAE J514
*'T' Port	3/8 SAE J514	1/2 SAE J514	1/2 SAE J514
*'F' Port	3/8 SAE J514	1/2 SAE J514	1/2 SAE J514
A1	45	52	52
A2	33	38	38
A3	28	36	36
A4	5.5	9	9

OUTPUT SHAFT INFORMATION			
	XL150 XL200 XL280	XL390 XL490 XL560	XL780 XL980 XL1120
C1	35	35	41
C2	10	7	7
C3	95.80/95.60	95.80/95.60	160.80/160.60
C4	173	170	247.5
C5	10.0	10	10
C6	20.0	20	20
C7	5	5	6
C8	M14-1.5P	M14-1.5P	M18-1.5P
C9	140	140	205

MOUNTING INFORMATION			
	XL150 XL200 XL280	XL390 XL490 XL560	XL780 XL980 XL1120
B1	237	298	298
B2	180.00/179.95	216.00/215.82	216.00/215.82
B3	196	211.6	246.6
B4	134	142	142
B5	62	70	105
B6	84	95	130
B7	12	16	16
B8	14.25/13.90	17.75/17.40	17.75/17.40
B9	210	265	265

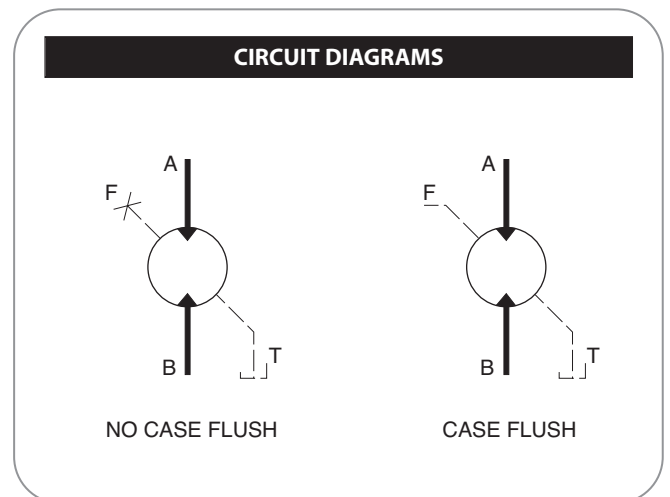

* Hydraulic connection sizes denote SAE 'O' ring boss size. These are not thread dimensions.

NOTES FOR MOUNTING

- A. For motors from 150 CC/Rev to 280 CC/Rev. All 12 mounting holes should be used for front or rear body mounting unless otherwise agreed by Rotary Power.
- B. For motors from 390 CC/Rev to 1120 CC/Rev. All 16 mounting holes should be used for rear body mounting.
- C. For motors from 390 CC/Rev to 1120 CC/Rev. Mount motor using 10 off M16 bolts (min grade 8.8) tightened to 210/220 Nm Torque.
- D. For motors from 780 CC/Rev to 1120 CC/Rev. Clamp 6 off remaining holes using M16 bolts (min grade 8.8) tightened to 210/220 Nm Torque.

X L R A D I A L P I S T O N M O T O R S

XLC COMPACT UNIT

Before finalising your installation please ask for a copy of the latest issue drawing.

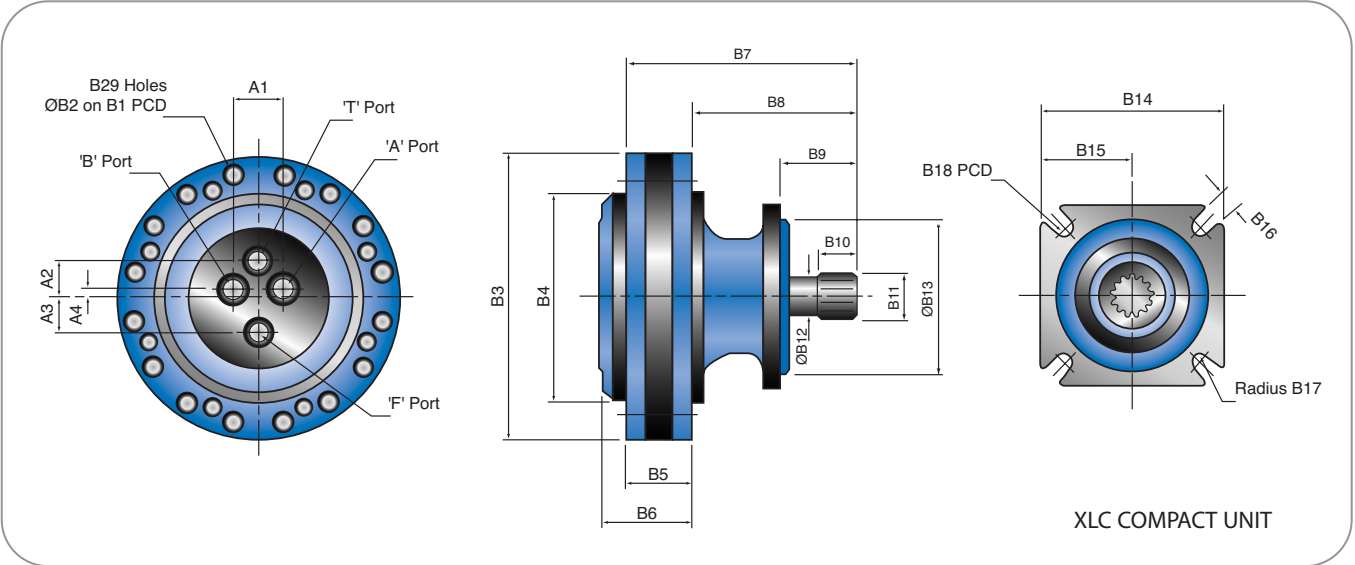

XLC & XLO DIMENSIONS

HYDRAULIC CONNECTIONS			
	XL150 XL200 XL280	XL390 XL490 XL560	XL780 XL980 XL1120
*'A' Port	5/8 SAE J514	5/8 SAE J514	5/8 SAE J514
*'B' Port	5/8 SAE J514	5/8 SAE J514	5/8 SAE J514
*'T' Port	3/8 SAE J514	1/2 SAE J514	1/2 SAE J514
*'F' Port	3/8 SAE J514	1/2 SAE J514	1/2 SAE J514
A1	45	52	52
A2	33	38	38
A3	28	36	36
A4	5.5	9	9

MOUNTING INFORMATION			
	XL150 XL200 XL280	XL390 XL490 XL560	XL780 XL980 XL1120
B1	210	265	265
B2	14.25/13.90	17.75/17.40	17.75/17.40
B3	237	298	298
B4	180.0/179.95	216.0/215.82	216.0/215.82
B5	66	69	104
B6	88	94	129
B7	170.4	206	241
B8	108.4	136	137
B9	55.4	75	75
B10	17.0	36.0	50

MOUNTING INFORMATION (cont)			
	XL150 XL200 XL280	XL390 XL490 XL560	XL780 XL980 XL1120
B11	ANSI B92.1 14T 12/24P	ANS B92.1 13T 8/16P	DIN5480 B50x2x24x7h
B12	26.7	37.0	49.5
B13	127.0/126.95	152.4/152.35	152.4/152.35
B14	148	200	200
B15	74	100	100
B16	14.0	20.6	20.6
B17	7.0	10.3	10.3
B18	160.0	228.6	228.6
B19	109	120	155
B20	77	97	97
B21	90	124	124
B22	160.04/160.00	190.04/190.00	190.04/190.00
B23	7.8	8.0	8.0
B24	BS3550 29T 16/32P (SP)	DIN5482 A50x45	DIN5480 70x3x30x22

* Hydraulic connection sizes denote SAE 'O' ring boss size. These are not thread dimensions.

XLO TORQUE UNIT

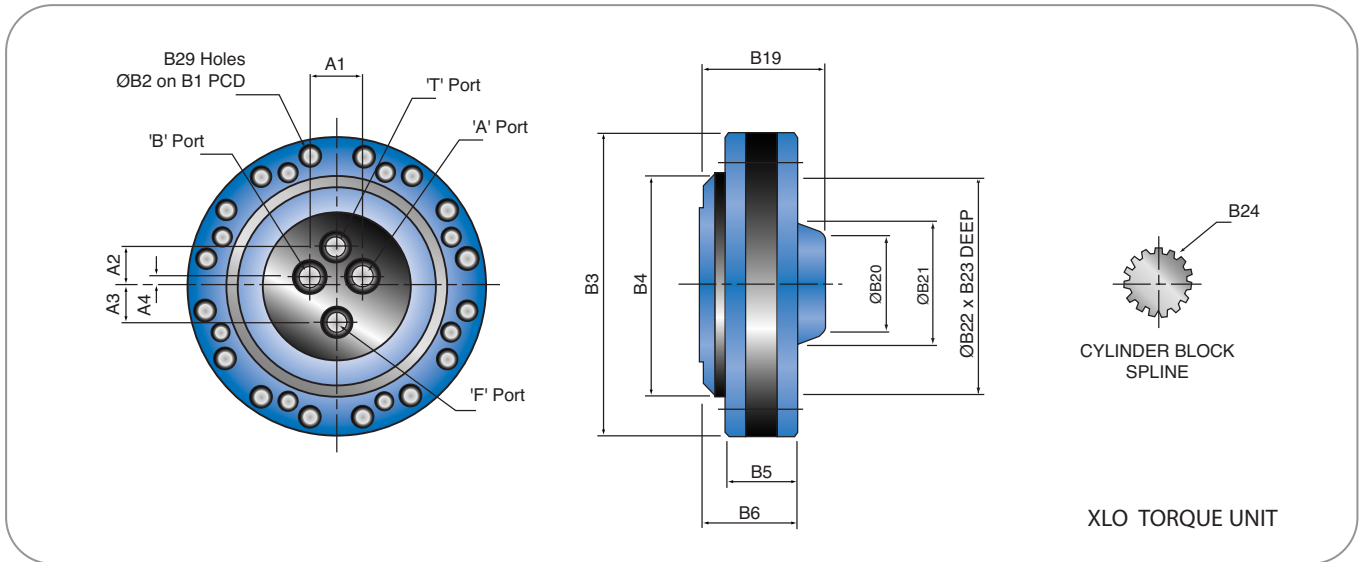

INSTALLATION

General

Do not remove protective plugs from main ports and drain connections until immediate connection into the system is to be made. Always examine the motor externally to check that damage has not been caused in transit.

Flange Mounting XLA, XLB, XLC

Provision is made for locating the motor by means of a machined spigot and four bolt flange (see installation details for dimensions) situated towards the shaft end of the output housing.

Case Mounting XLA, XLB, XLC, XLE

Provision is made for locating the motor by means of a machined spigot diameter on the front (for XLE only) and rear of the main casing assembly. If the front mounting is used a minimum of 8 bolts must be used. If the rear mounting is used a minimum of 12 bolts must be used for sizes upto 560 cc/rev. For larger motors a minimum of 10 bolts should be used for front mounting and 16 bolts for rear mounting.

Mounting XLA, XLB, XLC, XLE

The unit should be mounted on a flat machined face using the appropriate size bolts. The mounting surface pilot diameter should be machined to the nominal spigot diameter + 0.000" to + 0.027" (+0.0" to + 0.05"). Clearance should be made for the fillet radius between the motor location spigot and the motor mounting face.

Mounting Shaft Details XLA, XLB, XLC

Various standards of splined, keyed and tapered shafts are offered on the XL range. Check installation details for dimensions. Motor drives should be designed to eliminate unnecessary axial and radial loads, and thus prolong bearing life.

A keyed shaft is recommended for a flexible coupling output connection and a splined shaft when the driven shaft and motor are rigidly mounted.

Splines should at least be assembled and regularly lubricated with Molybdenum Dysulfide grease or preferably run in oil. Alignment of the two shafts should be where the driven shaft and motor are rigidly mounted. Alignment of the two shafts should be maintained within 0.05mm T.I.R.

Mounting Torque Unit XLO

Please contact Rotary Power for detailed recommendations.

Case Drain

A case drain line returned directly to tank should be connected to the "T" port located on the rear face of the motor. The "T" port should be positioned so that it is the uppermost port on the rear face of the motor. The bore size of the drain line should be big enough to allow leakage flow shown on page 4 without causing a back pressure at the motor case of more than that shown in performance data on page 2.

FLUSHING FLOW

High Speed/Temperature/Difference/Freewheel

A flushing flow will be required for high speed operation - see page 4 for details. If high temperature differentials of over 40°C (between motor temperature and bulk oil temperature) are envisaged, a case warming flow should be provided.

If freewheeling is part of your duty cycle, a case pressure needs to be developed by adding flow to the motor case using the "F" port and creating a back pressure in the drain line. The case pressure required above system pressure (port A and B) is given on page 4.

Case drain lines should be adequately sized (see case drain section above).

Please contact ROTARY POWER for detailed recommendations.

COMMISSIONING

READ THIS WITH OTHER COMPONENTS SUPPLIERS INSTRUCTIONS

1. During assembly thoroughly descale, clean and flush all pipework, fittings and reservoir during assembly.
2. Fill the system with new, filtered fluid that meets required specifications regarding viscosity at envisaged operating temperature, type and cleanliness for all components within the system, motor requirements are given on page 2 in performance data. The motor case must be filled with the above described fluid through the case drain (T) port, the drainline filled and reconnected.
3. Check the flow-rotation diagram below to ensure correct rotation for the installation.
4. Start the drive pump slowly
 - for engines turn over on the starter motor for a few seconds at a time.
 - For electric motor by a series of rapid on/off cycles.
 This is to ensure pump internal components are filled with oil. Run the system at high flow and low pressure, actuate all systems in all modes until all entrained air in system has been released.
5. Check and top-up fluid level if necessary.
6. Check and adjust settings where necessary in compliance with supplier's instructions to system requirements.
7. Check steady state operating temperature is in accordance with system and component requirements.
8. Check for and repair any leaks.
9. After the first few hours running, clean or renew (as appropriate) all filters

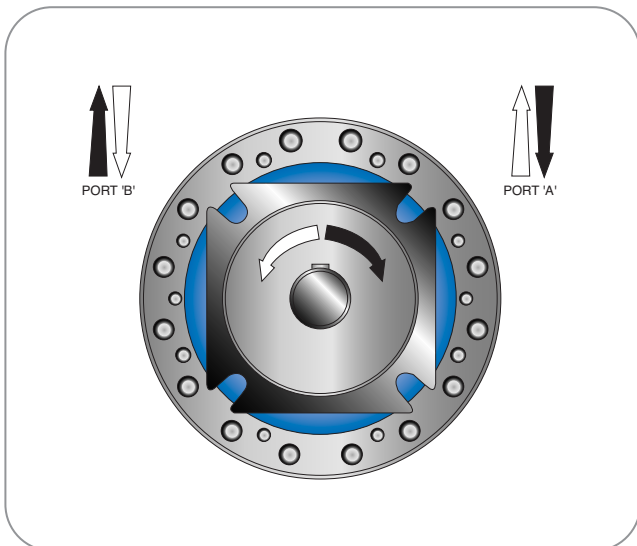

APPROXIMATE WEIGHTS Kg			
Weights	XL 15-28	XL 39-56	XL 78-11
XLO	21	30	35
XLA,B	28	43	48
XLC	26	39	44
XLE	28	43	48

IF IN DOUBT - CONSULT ROTARY POWER

SPECIAL OPTIONS

Air Bleed Port

For "shaft up" installations, an air bleed port should be specified and the leakage pipework should be arranged in a similar way to figure 1. This ensures that the bearings and the shaft seal are immersed in hydraulic oil.

If in doubt - please contact Rotary Power

Figure 1.

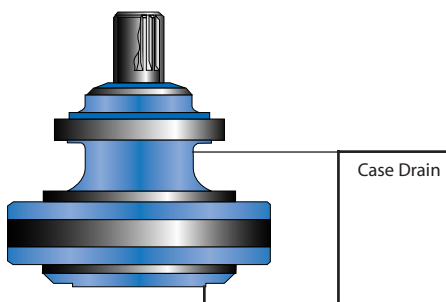

Speed Indication

A pulse pick-up port may be specified. Consult Rotary Power regarding preferred number of pulses/revolution and pulse pick-up thread size. Contact Rotary Power if alternative types of speed indication are required.

Mounting of Couplings or Gears to the Motor Shaft

Threaded holes can be included in the end of the shaft to assist the fitting of couplings, gears, etc. Consult Rotary Power for details.

Special Features

Consult Rotary Power if a special feature is required. Where it is practical, Rotary Power will engineer a custom design to match the specific need.

Flow Divider

Various flow divider configurations are possible. Please contact Rotary Power to discuss your requirements

X L R A D I A L P I S T O N M O T O R S

ORDER CODE

XL MOTOR BASIC MODEL CODE

X L E 5 6 G N 0 0 0 - -

XL SERIES

OUTPUT CASE STYLE

- O = Torque unit only
- A = SAE flange mount
- B = Metric flange mount
- C = Compact housing
- E = Wheel casing
- H = Torque unit fitted with "universal" gearbox adaptor

DISPLACEMENT

- 15 = 150 CM³
- 20 = 200 CM³
- 28 = 280 CM³
- 39 = 390 CM³
- 49 = 490 CM³
- 56 = 560 CM³
- 78 = 780 CM³
- 88 = 880 CM³
- 98 = 980 CM³
- 10 = 1050 CM³
- 11 = 1120 CM³

DESIGN SERIES

Factory specified

SPECIAL REQUIREMENTS IN CONSULTATION WITH ROTARY POWER

None = 00

BRAKE OPTION

- O = No brake
- B = Drum brake
- C = Disc brake

SEALS

- N = Nitrile (Standard)
- V = Viton

OUTPUT SHAFT

- O = Torque unit only
- A = SAE keyed shaft
- B = Metric keyed shaft
- C = XM keyed shaft
- D = SAE splined shaft
- E = Metric splined shaft
- F = XM splined shaft
- G = Wheel flange
- H = Taper shaft
- J = Quill shaft for option H case style
- K = HM keyed shaft

XLE 56GN000 - -

XL Motor
 Wheel casing, 560 CC/Rev.
 Standard wheel flange, Nitrile seals.
 No special requirements
 Design series - -

ENGLAND

ROTARY POWER
St. Peters
Newcastle upon Tyne
NE6 1BS
Tel: (0191) 276 4444
Fax: (0191) 276 4462
E. mail: rotary.power@bel.co.uk
www.rotarypower.com



USA

ROTARY POWER INC
2200 Wilson Road
Columbus
Ohio 43228, USA
Tel: (614) 876 8020
Fax: (614) 876 9029
E. mail: info@rotarypower.com
www.rotarypower.com

GERMANY

ROTARY POWER
Vertriebsgesellschaft mbH
Nordstrasse 78
52078 Aachen-Brand
Germany
Tel: (0241) 955190
Fax: (0241) 9551919
E. mail : info@rotarypower.de
www.rotarypower.com

